



INSTALLATION INSTRUCTIONS "C" & "D" SERIES ALUMINIUM SKIRTING DUCT

BASE

All base MUST be fitted level. Use of a chalk line is recommended.

All base MUST have a minimum clearance above the finished floor surface of 2mm. **DO NOT SIT DUCT AGAINST FLOOR.**

Any curvature in walls that will induce bowing in the installed base of greater than 1mm/metre MUST be corrected either prior to fitment (by others) or by appropriate packing (by installers). If excessive gapping exists behind fitted base, filling/finishing should be completed prior to cover fitment.

- **Fastener** spacing MUST not exceed 450mm and duct must be fastened in both Top & Bottom channels.
- **Earth/Alignment dowels** (provided) should be fitted (crimped) at every join between base sections. Mitre cutting of base is recommended at corners, however, internal corners may be overlapped.

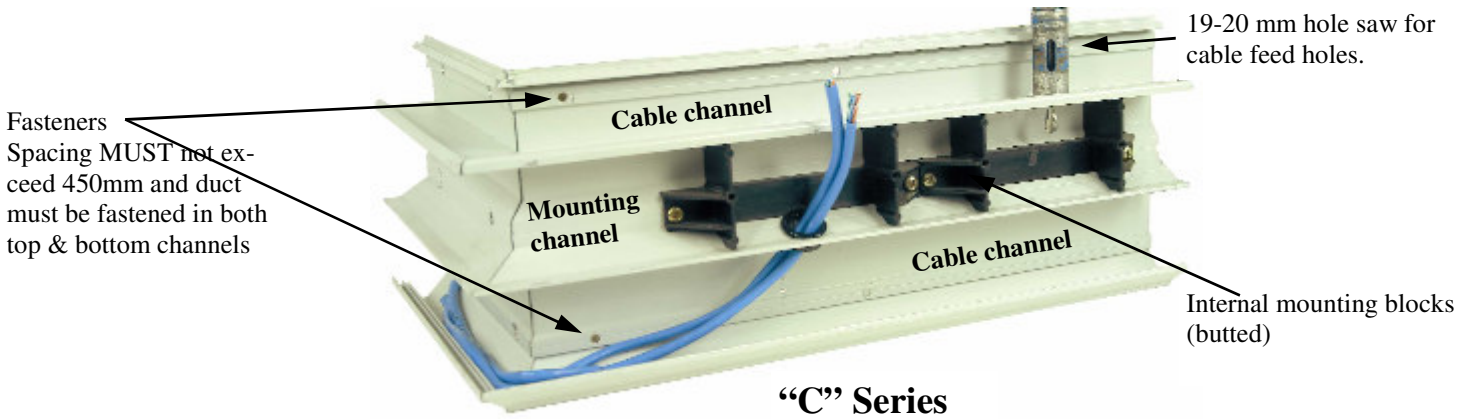

OUTLETS

- Mount internal block(s) (or boxes, D series) with screws provided.
- Drill cables feed holes (C series) or cut access to mount box (D series)
- Fit snap grommets provided (C series only)
- At this point outlets can be wired and installed complete with duct cover plate.
- Fix outlet to internal block / box by use of screws provided with the outlet. Screws may require shortening to a max length of 27mm.

NOTE: when using double and triple kits the internal mounting blocks / boxes, simply butt together.

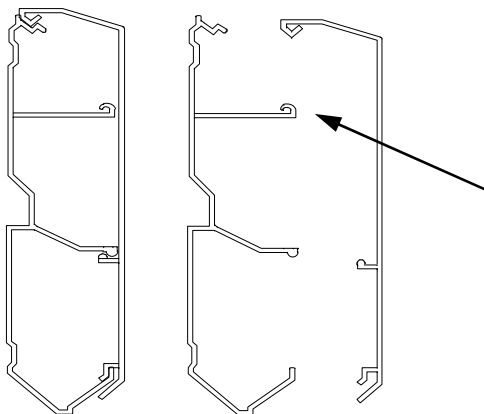

C Series base & cover 3 channel

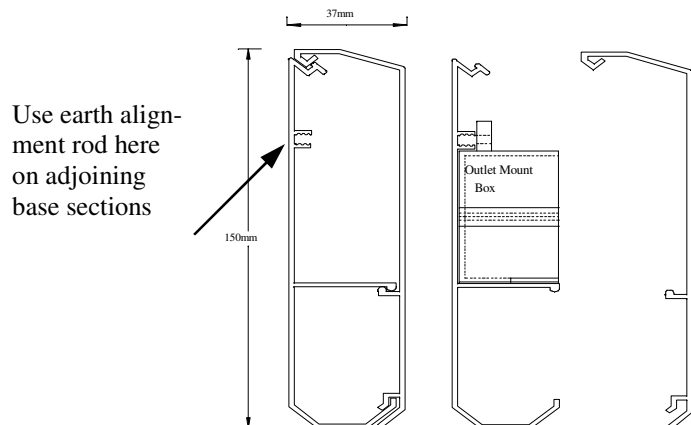

D Series base & cover 2 channel

COVERS (applies to both “C” & “D” Series duct - only “C” shown below)

- Locate the bottom slot of the cover over the bottom rail of the base (see Fig 5)
- Apply downward and forward pressure onto the cover to ensure the cover bead clicks UNDER the base location bead.
- Snap the top edge of the cover into place
- Corners are accomplished by use of modular corners, see figs 3 & 4. It is recommended that the small screw provided is used, as in figure 4, to ensure external corners cannot be dislodged in high traffic areas.

Note: *Spray and Wipe* or similar cleaners should be used to remove dirt or grime after installation is complete.

All duct must be installed to comply with AS3000. If you have any queries regarding fitment or compliance with standards, please call our helpline.

Certificate of suitability CS/848/Q.

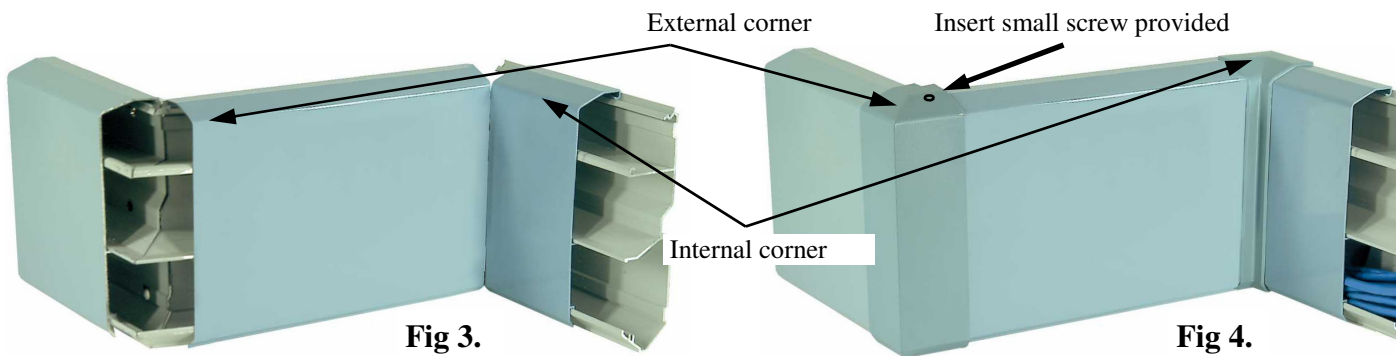

Straight cut covers, before corners fitted

Modular corners snap fit over straight cuts.

